



Magnetically controlled liquid level gauge type UHF

The product line UHF is used wherever fluid level has to be monitored, indicated, and controlled in a reliable way, especially with corrosive, toxic and inflammable fluids.

The UHF level indicators offer a reliable, accident-free and maintenance-free usage, through a simple and break-resistant construction at a maximum process pressure of 64 bar and a temperature range from -40 through $350\text{ }^{\circ}\text{C}$. The fluid level is indicated directly with a separation of the measurement and indication area. The magnetic transfer of the fluid level from the tank to the indicator is continuous and vibration-resistant, even in the case of fast changing levels.

It is possible to mount the indication rail in any position on the pipe diameter. There is no corrosion of the indication system. The UHF instruments may be used in open or closed vessels. A definite level measurement without any power supply is guaranteed due to a continuous rotation of the wafers, even if a power loss in the plant occurs.

Functional principle:

A float chamber is connected to the tank, and following the law of communicating tubes, the level in the float chamber is equal to the level of the tank. The float (3) follows the fluid level and transmits its movements contact-free to the indication rail (4) mounted on the outside. The float has a special magnet, which rotates the wafers by 180° as it passes them. The result is a clearly defined level indication, with the level shown in a continuous red stripe strongly contrasted to the white above. At increasing levels the color of the wafer changes from white to red and vice versa.

The indication rail and the wafers are made of ABS so that there will never be a problem of corrosion in humid and aggressive atmosphere. Each wafer has a permanent magnet, that is why the indicator is shock proof.

All models are available with electronic alarms, that can be mounted at any position during operation of the system, which renders possible an optimal definition of the min. and max. data points.

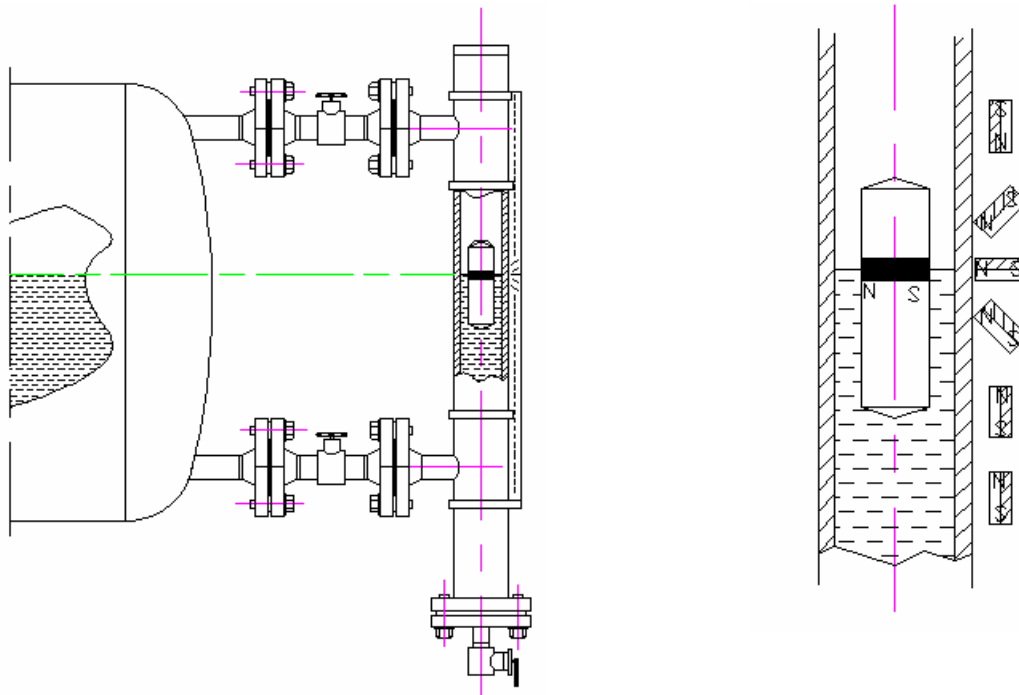

2.2 Level measurement tasks

- 1.) Indicating the fluid level
- 2.) Monitoring the level with alarm contacts



3.) Transferring the level using measurement value sensors (analogue signal 4-20 mA) to electrical display units

2.3 Advantages

No risk of glass breakage as a result of the separation of the measurement and indicator areas. The float principle means that changes of the density in the medium have very little influence on the indication accuracy.

2.4 Switches / Alarm contacts

Magnetic level indicators can be equipped with an arbitrary number of switch contacts. In contrast to electric float switches, switch contacts may be installed at any position of the stand pipe. Wherever additional float chambers are needed for float switches, magnetically controlled level gauges offer a considerable price benefit.

Electrical level measurement transducers which use the displacement principle must be recalibrated each time the fluid density has changed. The price of a magnetically controlled level indicator with integral electrical measurement transducer is considerably lower than level measurement transducers. The reed chain with an R/I measurement transducer can be changed without interrupting the operation. The measurement chamber is hermetically sealed – there is no contact between the fluid chamber and the reed chain.

The switches / alarm contacts are secured with pipe clips, and can be adjusted to any desired height. The connection is using 3 or 2-core cable or casing terminals. The changeover contact can be used as opener or closer. The switches are also available as explosionproof version.

2.5 Floats

The construction of the float requires a great amount of technical knowledge. The float with its special magnet can rotate freely in the float chamber.

The float materials are stainless steel, 304,316, or U-PVC, PP, . Floats are used from a minimum density of 0,35

kg/dm³. all of the floats are sealed.

2.6 Indication rail

The UHF level gauges can be supplied with indication rails made from 2 different materials. ABS indication rails are resistible to breakage. The max. permissible media temperature is 80°C, with 20°C ambient temperature and natural convection as test conditions.

Aluminum indication rails can be supplied as one part rail up to a length of 5 m. The sight cover material depends

on the temperature, up to 150°C the material is ABS and up to 400°C it is glass.

2.7 Materials

The gauge chamber and the floats are made of stainless steel , 304,316, U-PVC, PP. Other materials on request.

2.8 Special versions

1. Transmitter, output signal 4-20 mA
2. Steam jacket, e.g. for viscous media
3. Float chamber with Armaflex insulation, for temperatures below zero (centigrade)
4. Two-parts versions without interruption of the indication, for measuring lengths > 5 m



Technical specifications magnetic level gauge type UHF-1 PN6 Bar

Principle : Communicating tubes with magnetic float	<p>The diagram illustrates a vertical magnetic level gauge. It consists of a main tube (1) with a float (2) inside. The tube is connected to a process pipe via a flange (4) and a gasket (3). The gauge is mounted on a base (5). Dimensions are indicated: A is the height from the base to the top flange; B is the height from the top flange to the float; C is the diameter of the tube; L is the total height of the gauge. The float is shown in a liquid level, with a magnetic float (2) and a magnetic float (1) indicated.</p>
Mounting position : Vertical	
Measuring range : Max. 5500 mm (one part) > 5500 mm 2- or multipart	
Pipe size : 51 x 1.5 mm welded, 57 x 2 mm seamless, Buttweld construction with Tpieces	
Process connections : to specify: Flanged: DN15-40 (½ -1 ½" 150# RF) Welding of threaded stud Flanged DN50 (2" 150# RF)	
Vent/drain connections : Plugged R½" (Other request also available)	
Pipe material : SS, 304, 316 (Other pipe materials also available)	
Flange material : as pipe material ALSO CAN USE Carbon steel	
Float material : SS, 304, 316,PP	
Operation temperature : -40 to + 350°C	
Operation pressure : Max. 6 bar	
Density :min. 0,35 kg/dm ³	
Bolts/Nuts : CS , SS	
Gaskets: : PTFE up to 100°C Klingersil up to 350°C	
Indication rail : ABS up to 80°C ABS+Aluminium up to 200°C Aluminium up to 350°C	
Float types: : Cylindrical, sealed type Length:DEPEND ON DENSTY	



Technical specifications magnetic level gauge type UHF-1-V/ UHF-1-P PN6 Bar

Principle : Communicating tubes with magnetic float	<p>The diagram shows a vertical cross-section of a magnetic level gauge. It consists of a main pipe (1) with a float (2) inside. The float is connected to a magnetic assembly (3) at the bottom. The gauge is mounted on a base (4) with a flange. A dimension line labeled 'L' indicates the 'measure length' from the top of the pipe to the bottom of the float. Other dimensions include 'A' (total height), 'B' (height to the top of the float), and 'C' (width of the base). A small detail (5) is shown at the bottom right.</p>
Mounting position : Vertical	
Measuring range : Max. 3600 mm (one part) > 3600 mm 2- or multipart	
Pipe size : 63 x 4.7 mm seamless Buttweld construction with Tpieces	
Process connections : to specify: Flanged: Flanged: DN15-40 (1/2 - 1 1/2" 150# RF)	
Vent connections : Plugged R1/2" (Other request also available)	
Pipe material : U-PVC (UHF-1-V),PP(UHF-1-P)	
Flange material : as pipe material	
Float material : U-PVC (UHF-1-V),PP(UHF-1-P)	
Operation temperature : -20 to + 80°C for U-PVC -30 to + 70°C FOR PP	
Operation pressure : Max. 6 bar	
Density : 0,7 kg/dm ³ *	
Bolts/Nuts : SS	
Gaskets : PTFE	
Indication rail : ABS up to 80°C	
Float types: : Cylindrical, sealed type Length: DEPEND ON DENSTY	



Technical specifications magnetic level gauge type UHF-2 PN10 Bar

Principle : Communicating tubes with magnetic float	<p>The diagram shows a vertical magnetic level gauge assembly. It consists of a main pipe with a float inside. The float is connected to a magnetic coupling system. The assembly includes a top flange (4), a main pipe (1), a float (2), a bottom flange (3), and a bottom valve assembly (5). Dimensions are indicated: A is the height from the bottom valve to the top flange, B is the height from the top flange to the float, L is the total height from the bottom valve to the top flange, and C is the diameter of the pipe. The float is shown in a liquid level.</p>
Mounting position : Vertical	
Measuring range : Max. 5500 mm (one part) > 5500 mm 2- or multipart	
Pipe size : 51 x 1.5 mm welded, 57 x 2 mm seamless, Buttweld construction with Tpieces	
Process connections : to specify: Flanged: DN15-40 (½ -1 ½" 150# RF) Welding of threaded stud Flanged DN50 (2" 150# RF)	
Vent/drain connections : Plugged R½" (Other request also available)	
Pipe material : SS, 304, 316 (Other pipe materials also available)	
Flange material : as pipe material ALSO CAN USE Carbon steel	
Float material : SS, 304, 316,	
Operation temperature : -40 to + 350°C	
Operation pressure : Max. 10 bar	
Density :min. 0,35 kg/dm ³	
Bolts/Nuts : CS , SS	
Gaskets: : PTFE up to 100°C Klingersil up to 350°C	
Indication rail : ABS up to 80°C ABS+Aluminium up to 200°C Aluminium up to 350°C	
Float types: : Cylindrical, sealed type Length:DEPEND ON DENSTY	



Technical specifications magnetic level gauge type UHF-3 PN16 Bar

Principle : Communicating tubes with magnetic float	<p>The diagram illustrates a vertical magnetic level gauge. It features a main tube with a float inside. The float is cylindrical and sealed. The gauge has two flanges, labeled 4, for process connections. The total height of the gauge is labeled L, and the height of the float is labeled B. The distance from the bottom of the gauge to the top of the float is labeled A. The diameter of the gauge is labeled C. The gauge is mounted on a base, labeled 5, which has a threaded connection. The gauge is labeled 1 and 2.</p>
Mounting position : Vertical	
Measuring range : Max. 5500 mm (one part) > 5500 mm 2- or multipart	
Pipe size : 57 x 2 mm seamless, 51 x 1.5 mm welded, Buttweld construction with Tpieces	
Process connections : to specify: Flanged: DN15-40 (½ -1 ½" 150# RF) Welding of threaded stud Flanged DN50 (2" 150# RF)	
Vent/drain connections : Plugged R½" (Other request also available)	
Pipe material : SS, 304, 316 (Other pipe materials also available)	
Flange material : as pipe material ALSO CAN USE Carbon steel	
Float material : SS, 304, 316,	
Operation temperature : -40 to + 350°C	
Operation pressure : Max. 16 bar	
Density :min. 0,35 kg/dm ³	
Bolts/Nuts : CS , SS	
Gaskets: : PTFE up to 100°C Klingersil up to 350°C	
Indication rail : ABS up to 80°C ABS+Aluminium up to 200°C Aluminium up to 350°C	
Float types: : Cylindrical, sealed type Length:DEPEND ON DENSTY	



Technical specifications magnetic level gauge type UHF-5 PN25 Bar

Principle : Communicating tubes with magnetic float	<p>The diagram illustrates a vertical magnetic level gauge. It consists of a main pipe (1) with a float (2) inside. The float is connected to a magnetic assembly (3) at the bottom. The gauge is mounted on a pipe with a diameter of 57 x 2 mm. The drawing shows the gauge in a vertical position, with a dashed line indicating the float's position within the liquid. The gauge is labeled with numbers 1 through 5, corresponding to the technical specifications. Dimension A is the total height of the gauge, B is the height of the upper section, C is the diameter of the pipe, and L is the measuring length. The float is shown in a cylindrical, sealed type.</p>
Mounting position : Vertical	
Measuring range : Max. 5500 mm (one part) > 5500 mm 2- or multipart	
Pipe size : 57 x 2 mm seamless, Buttweld construction with Tpieces	
Process connections : to specify: Flanged: DN15-40 (1/2 -1 1/2" RF) Welding of threaded stud	
Vent/drain connections : Plugged R1/2" (Other request also available)	
Pipe material : SS, 304, 316 (Other pipe materials also available)	
Flange material : as pipe material ALSO CAN USE Carbon steel	
Float material : SS, 304, 316,	
Operation temperature : -40 to + 350°C	
Operation pressure : Max. 25 bar	
Density :min. 0,35 kg/dm ³	
Bolts/Nuts : CS , SS	
Gaskets: : PTFE up to 100°C Klingersil up to 350°C	
Indication rail : ABS up to 80°C ABS+Aluminium up to 200°C Aluminium up to 350°C	
Float types: : Cylindrical, sealed type Length:DEPEND ON DENSTY	



Technical specifications magnetic level gauge type UHF-6 PN40 Bar

Principle :	Communicating tubes with magnetic float
Mounting position :	Vertical
Measuring range :	Max. 5500 mm (one part) > 5500 mm 2- or multipart
Pipe size :	57 x 2 mm seamless, Buttweld construction with Tpieces
Process connections :	to specify: Flanged: DN15-40 (1/2 -1 1/2" RF) Welding of threaded stud
Vent/drain connections :	Plugged R1/2" (Other request also available)
Pipe material :	SS, 304, 316 (Other pipe materials also available)
Flange material :	as pipe material ALSO CAN USE Carbon steel
Float material :	SS, 304, 316,
Operation temperature :	-40 to + 350°C
Operation pressure :	Max. 40 bar
Density :	min. 0,35 kg/dm ³
Bolts/Nuts :	CS , SS
Gaskets :	PTFE up to 100°C Klingersil up to 350°C
Indication rail :	ABS up to 80°C ABS+Aluminium up to 200°C Aluminium up to 350°C
Float types:	: Cylindrical, sealed type
Length:	DEPEND ON DENSTY

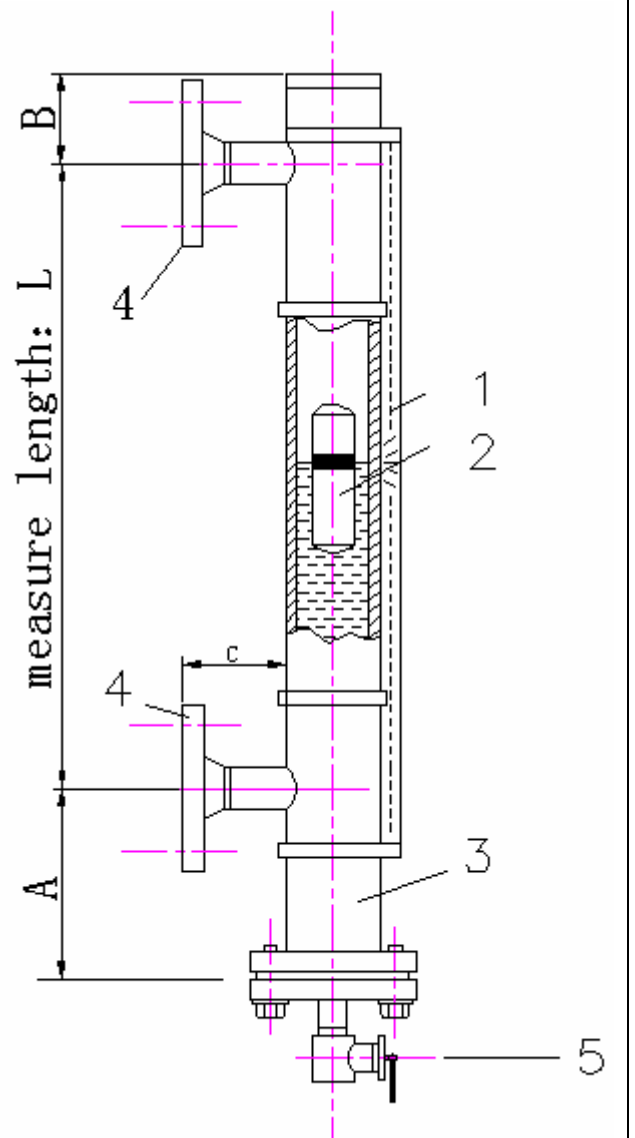



Technical specifications magnetic level gauge type UHF-7 PN64 Bar

Principle : Communicating tubes with magnetic float	<p>The diagram shows a vertical magnetic level gauge assembly. It consists of a main pipe with a float inside. The float is connected to a magnetic coupling system. The assembly includes a top flange (4), a main pipe (1), a float (2), a bottom flange (3), and a base (5). Dimensions are labeled: A is the height from the base to the top flange, B is the height from the top flange to the float, L is the total height from the base to the top flange, and C is the diameter of the pipe. The float is shown in a liquid level, with a magnetic coupling system (1 and 2) connected to the float.</p>
Mounting position : Vertical	
Measuring range : Max. 5500 mm (one part) > 5500 mm 2- or multipart	
Pipe size : 57 x 3 mm seamless, Buttweld construction with Tpieces	
Process connections : to specify: Flanged: DN15-40 (1/2 - 1 1/2" RF) Welding of threaded stud	
Vent/drain connections : Plugged R1/2" (Other request also available)	
Pipe material : SS, 304, 316 (Other pipe materials also available)	
Flange material : as pipe material ALSO CAN USE Carbon steel	
Float material : SS, 304, 316,	
Operation temperature : -40 to + 350°C	
Operation pressure : Max. 64 bar	
Density :min. 0,5 kg/dm ³	
Bolts/Nuts : CS , SS	
Gaskets : : PTFE up to 100°C Klingersil up to 350°C	
Indication rail : ABS up to 80°C ABS+Aluminium up to 200°C Aluminium up to 350°C	
Float types: : Cylindrical, sealed type Length:DEPEND ON DENSTY	



Technical specifications magnetic level gauge type UHF-1D-V/ UHF-1D-P PN6 Bar

Principle : Communicating tubes with magnetic float	
Mounting position : TOP OF TANK	
Measuring range : Max. 2500 mm	
Pipe size : 63 x 4.7 mm seamless 75 x 3 mm seamless for tube	
Process connections : to specify: Flanged: DN80-100	
Vent connections : NO (Plugged R1½"Other request also available)	
Pipe material : U-PVC (UHF-1D-V), PP(UHF-1D-P)	
Flange material : as pipe material	
Float material : U-PVC (UHF-1D-V),PP(UHF-1D-P)	
Operation temperature : -20 to + 80°C for U-PVC -30 to + 70°C FOR PP	
Operation pressure : Max. 6 bar	
Density : 0,7 kg/dm ³ *(DEPEND ON LENGTH)	
Bolts/Nuts : CS, SS	
Gaskets : PTFE	
Indication rail : ABS up to 80°C	
Float types : Cylindrical, sealed type Length: DEPEND ON DENSTY	



Technical specifications magnetic level gauge type UHF-2D PN10 Bar

Principle : Communicating tubes with magnetic float	
Mounting position : TOP OF TANK	
Measuring range : Max. 2500 mm (one part) > 2500 mm 2- or multipart	
Pipe size : 51 x 1.5 mm welded, 57 x 2 mm seamless,	
Process connections : to specify: Flanged: DN100-150 RF Welding of threaded stud	
Vent connections : NO (Plugged R $\frac{1}{2}$ " Other request also available)	
Pipe material : SS, 304 (Other pipe materials also available)	
Flange material : as pipe material ALSO CAN USE Carbon steel	
Float material : SS, 304, 316,	
Operation temperature : -40 to + 350°C	
Operation pressure : Max. 10 bar(depend on density)	
Density :min. 0,7 kg/dm ³ DEPEND ON LENGTH	
Bolts/Nuts : CS , SS	
Gaskets : PTFE up to 100°C Klingersil up to 350°C	
Indication rail : ABS up to 80°C ABS+Aluminium up to 200°C Aluminium up to 350°C	
Float types: : Cylindrical, sealed type Length: DEPEND ON DENSTY	



LEVEL TRANSMITTER

Measuring principle:

The resistance chain with the reed contacts are built in a pipe made of Stainless Steel. This so-called "Reed-chain" is mounted on the float chamber with tube clamps. According to the movement of the float, the float magnet closes one reed contact which produces a resistance proportional to the height of the liquid in the tank. You get a near-analogous output signal, with a resolution of about 10 mm, 20mm, or 5mm.

Then the reed chain with an R/I measurement transducer can be changed without interrupting the operation. To change the level to 4~20mA proportional.

The resistance chain receives it's power supply from the transmitter. The 4...20 mA transmitter output signal can be transferred to an indicator or can be used to drive alarm contacts.

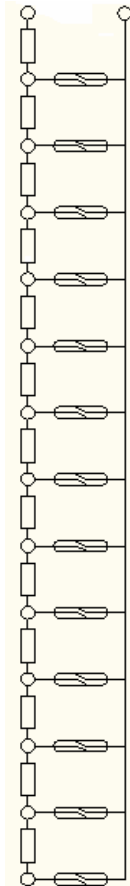
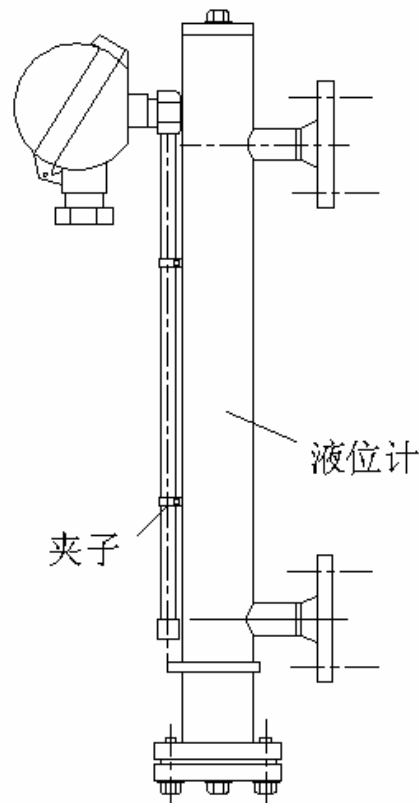



Max. medium temperature: 150 °C

For higher temperature(up to 350°C) need Heat protection:

Protection pipe: Φ19 mm

Resolution: 10mm 20mm 5mm

Material: SS,or 304SS

Enclosure: IP65

Out signal: 4~20mA (HART optional)

Power supply: 24VDC two-lines

Approval: ExdIICT5



COMPANY NAME: Xi'an XiangYuan Science and Technology Co.,ltd

Post address: 1/F Ministrant of A2, Standard factory, New industrial park, Hi-tech Zone,

Xi'an 710119 PR. CHINA.

TEL: 0086-29-85690252 , 88608386

FAX: 0086-29- 88882045

e-mail: xiangyuanst@126.com

www.xiangyuanst.com